

COPY TO BE SENT BACK SIGNED FOR ORDER APPROVAL

DATE:

STAMP AND SIGNATURE:

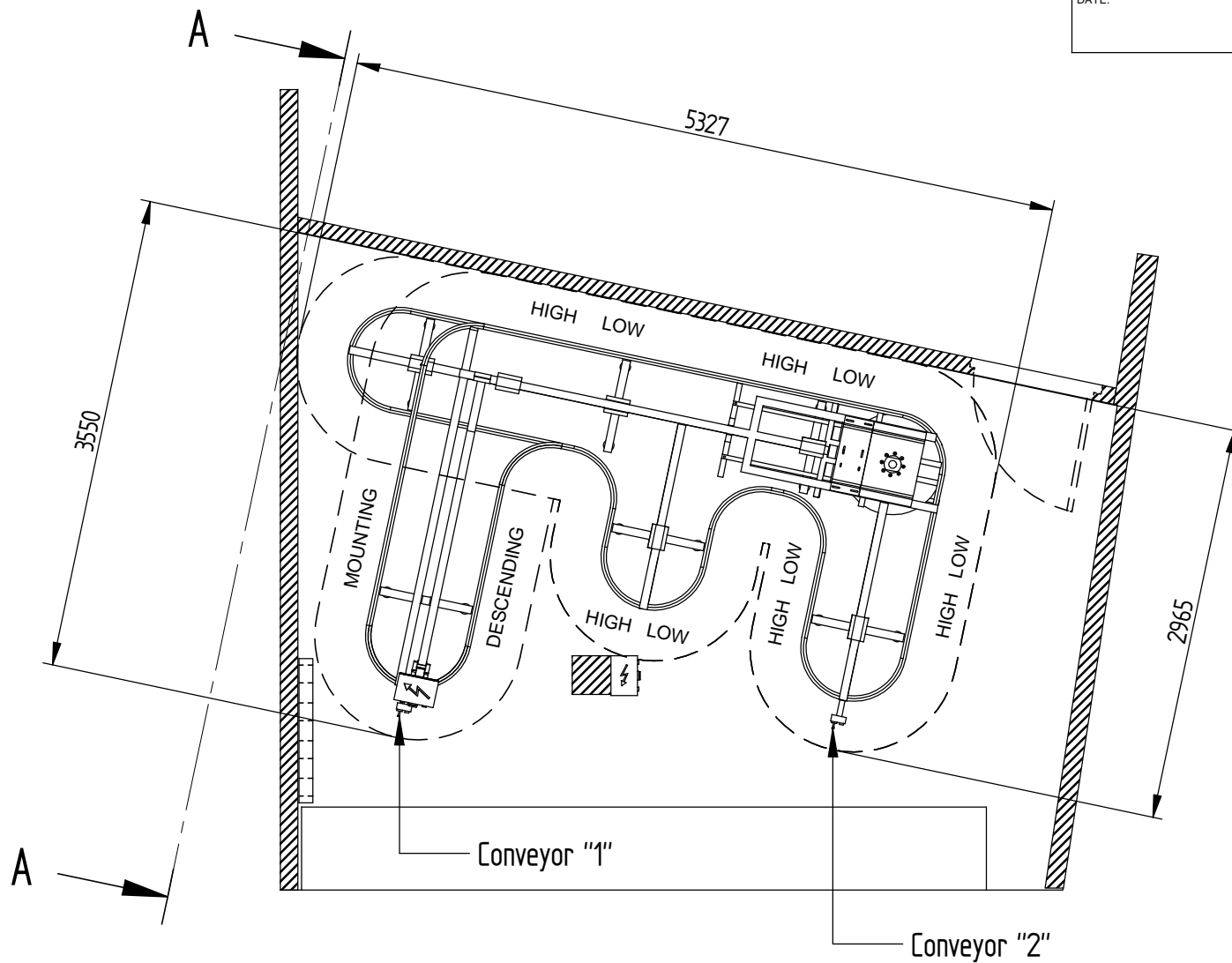

CAPACITY OF CONVEYOR "1" approx. 510 slots interaxis of 33 mm. When storing particularly bulky garments such as those which are usually present in a cloakroom, it is not always possible to place one garment in every slot, but it may be necessary to skip one every so often in order to recuperate space width ways. According to our experience, we consider that by using hanger of reduced width, such as those supplied by us, it is possible to position up to one garment every 50 mm. Assuming such a value, we are able to store up to 330-340 bulky garments.

CAPACITY OF CONVEYOR "2" approx. 420 slots interaxis of 33 mm.

Considering the above-mentioned remarks, we are able to store up to 275-285 bulky garments on this conveyor too.

TOTAL CAPACITY CONVEYORS "1+2" approx. 930 slots interaxis of 33 mm., 605-625/p (50 mm.)

COPY TO BE SENT BACK SIGNED FOR ORDER APPROVAL

DATE:

STAMP AND SIGNATURE:

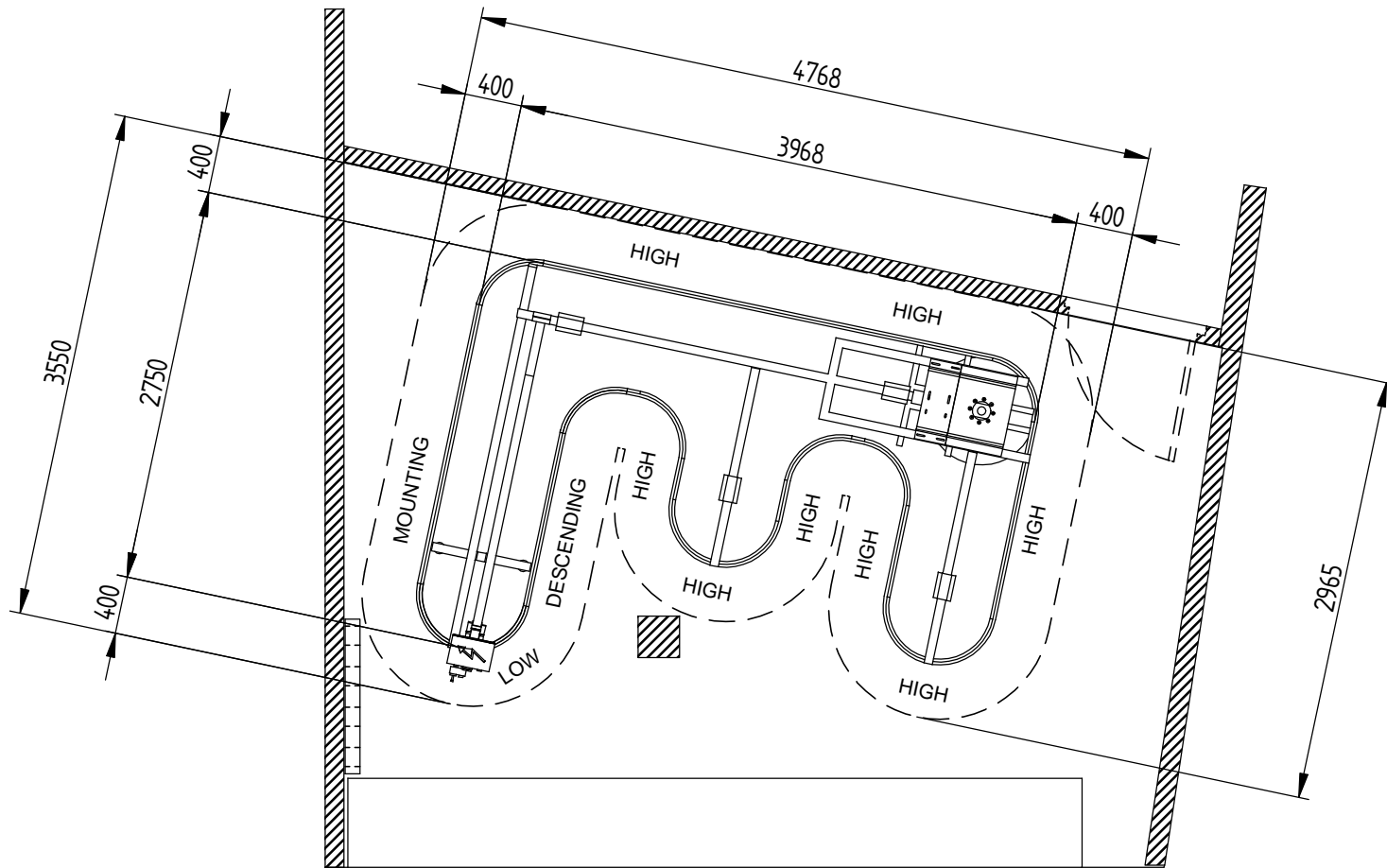

Conveyor "1"

COPY TO BE SENT BACK SIGNED FOR ORDER APPROVAL

DATE:

STAMP AND SIGNATURE:

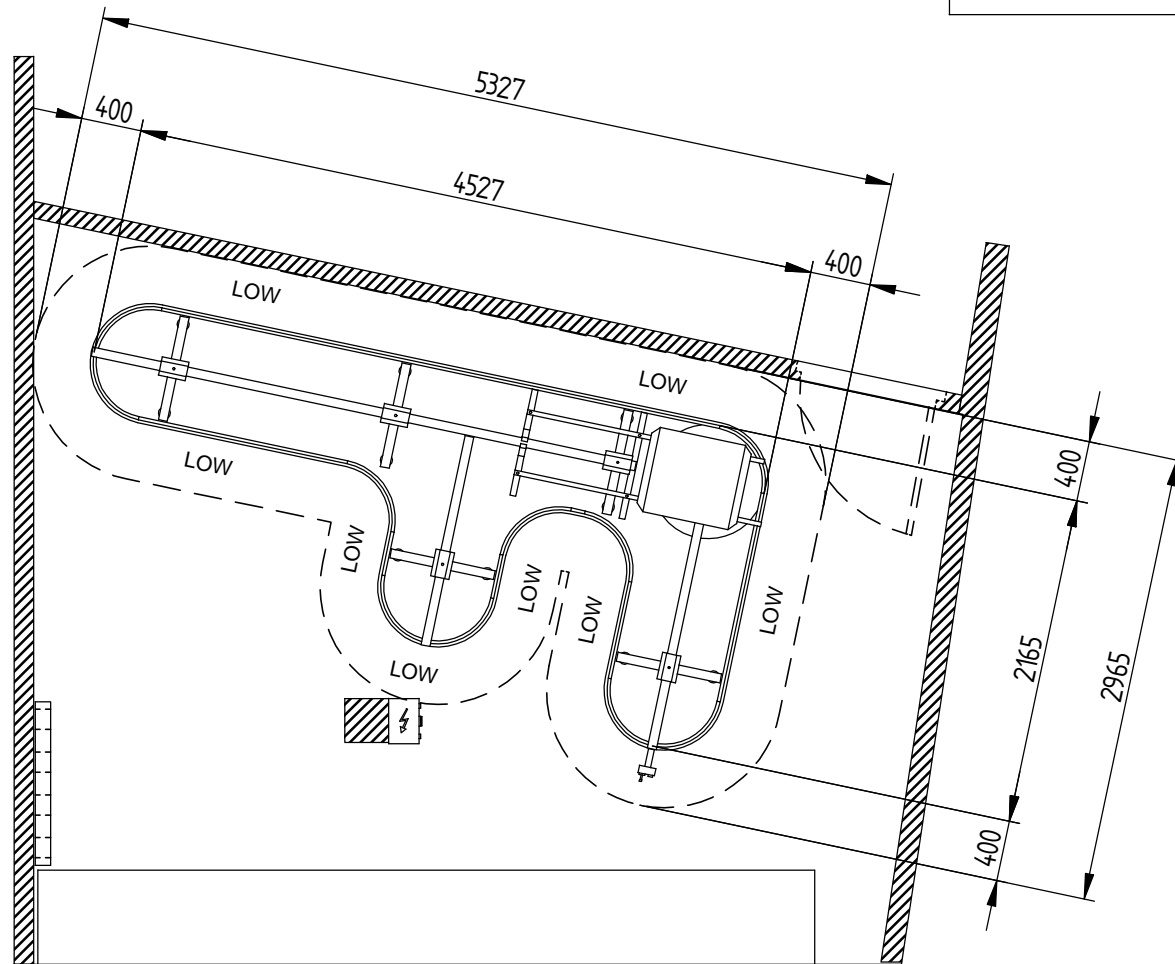

Conveyor "2"

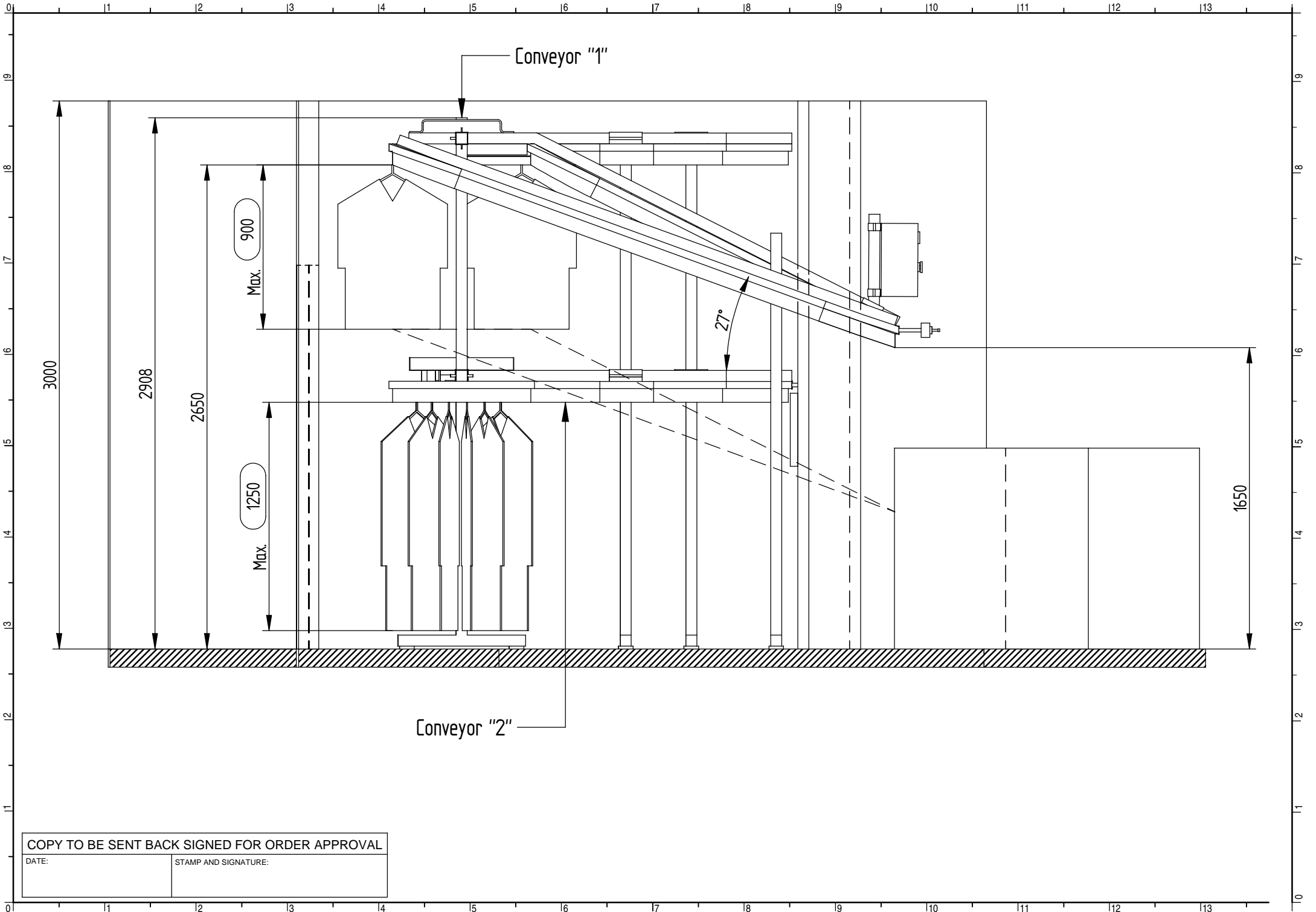

COPY TO BE SENT BACK SIGNED FOR ORDER APPROVAL

DATE:

STAMP AND SIGNATURE:

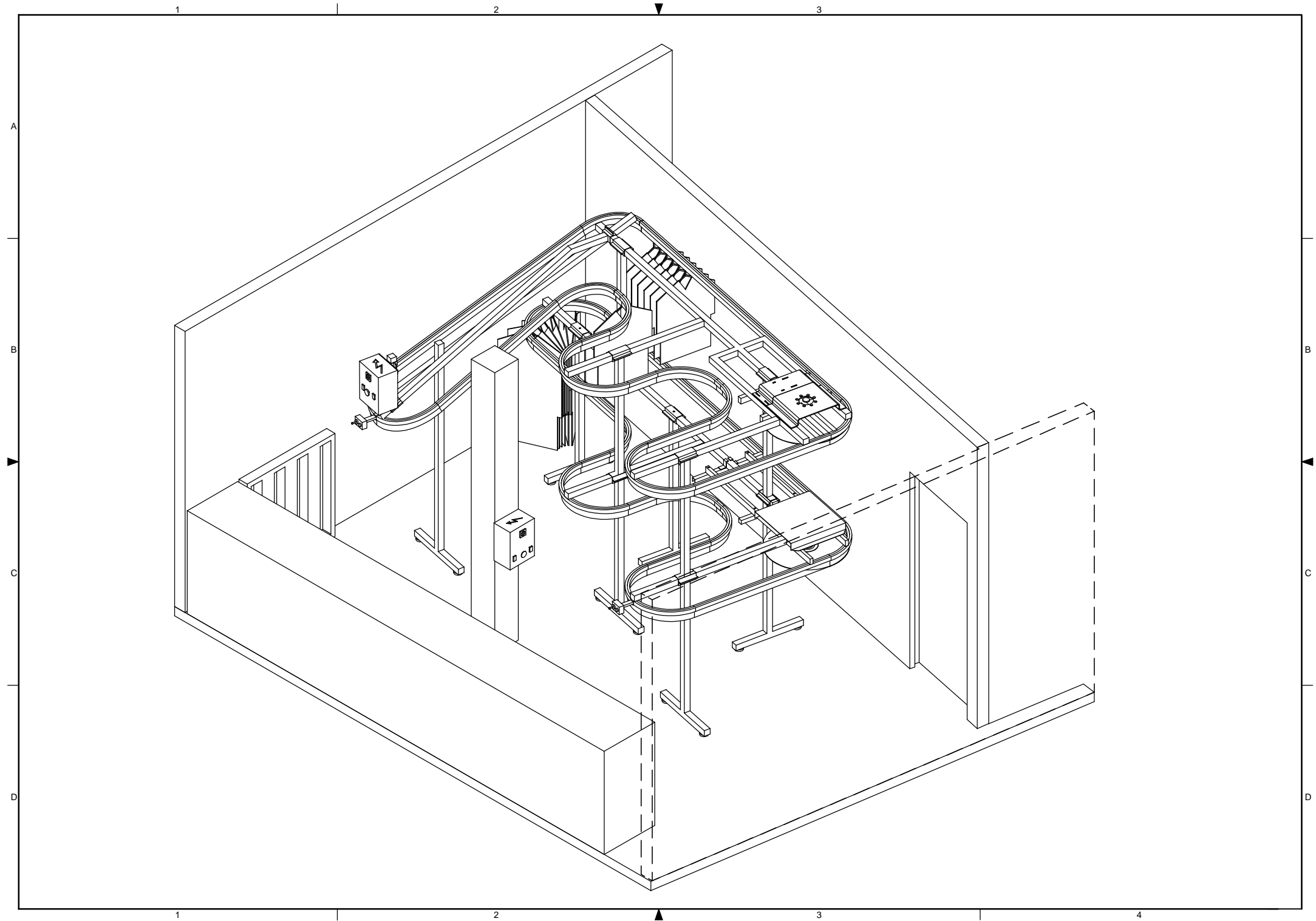

COPY TO BE SENT BACK SIGNED FOR ORDER APPROVAL

DATE:

STAMP AND SIGNATURE:

